

# U-LA Large PV Array Mounting System—Ground

## With Steel Connectors for 2- or 3-Inch Schedule 40 Steel Pipe

### *Installation Manual 302.1*



This manual is intended for use by the professional installer in conjunction with your *U-LA Component Specifications & Price Quote* (hereafter **Specs Sheet**), which has been supplied by UniRac for your unique installation. Please review both documents completely before proceeding.

***The Specs Sheet is specific to your site.  
Do not apply it to other installations.***

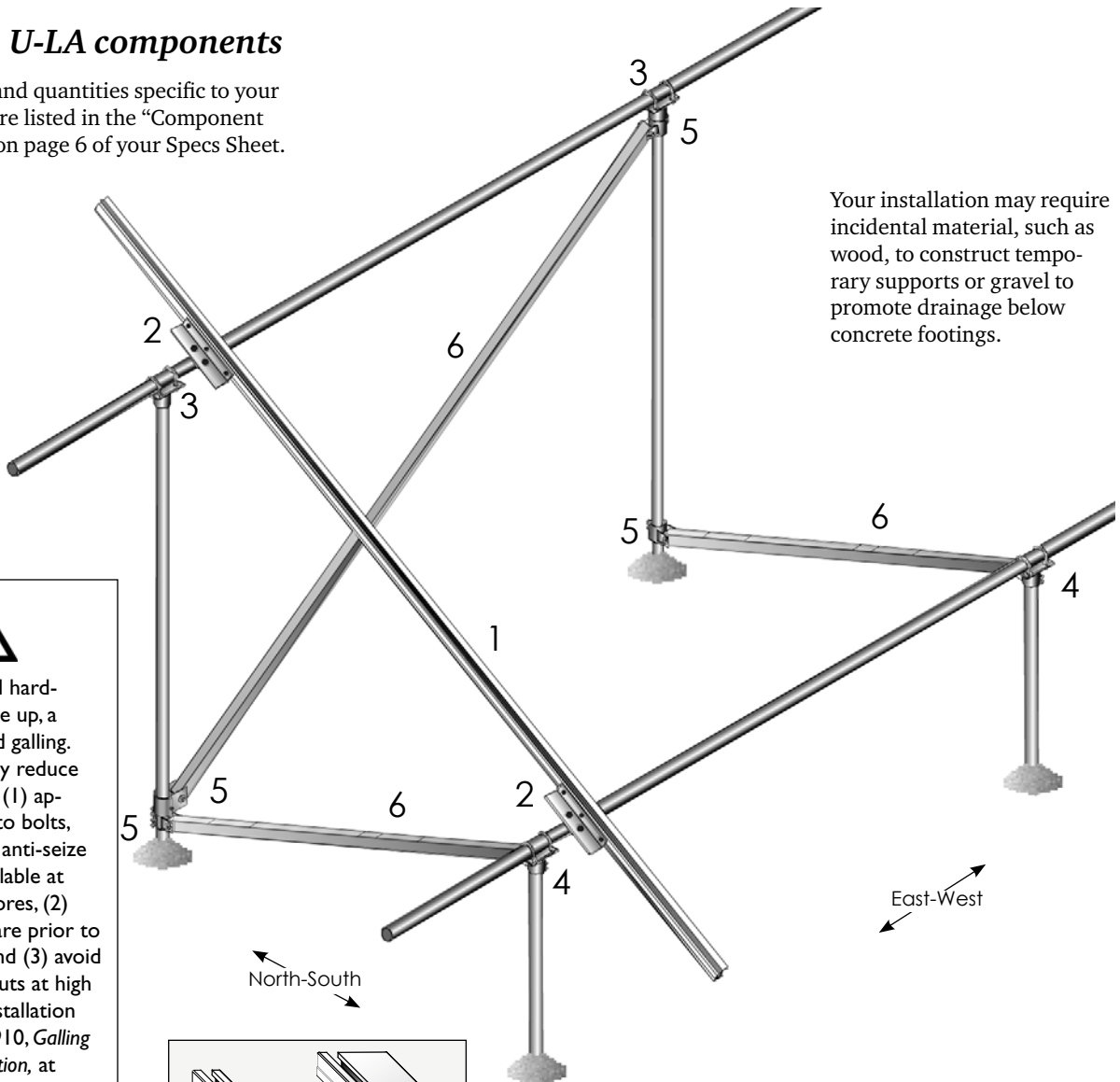
## Installer responsibility

The installer is solely responsible for:

- Complying with all local or national building codes, including any that may supercede this manual.
- Ensuring that UniRac and other products are appropriate for the particular installations and installation environment.
- Ensuring safe installation of all electrical aspects of the PV array.

**Figure 1. U-LA components**

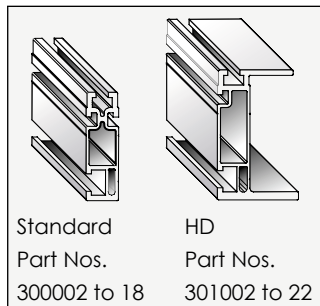
Components and quantities specific to your installations are listed in the “Component Packing List” on page 6 of your Specs Sheet.



Your installation may require incidental material, such as wood, to construct temporary supports or gravel to promote drainage below concrete footings.

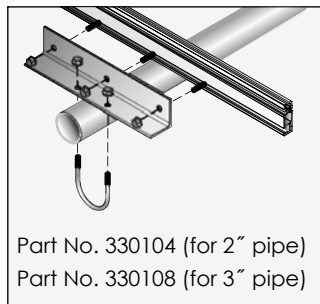


Stainless steel hardware can seize up, a process called galling. To significantly reduce its likelihood, (1) apply lubricant to bolts, preferably an anti-seize lubricant, available at auto parts stores, (2) shade hardware prior to installation, and (3) avoid spinning on nuts at high speed. See Installation Supplement 910, *Galling and Its Prevention*, at [www.unirac.com](http://www.unirac.com).

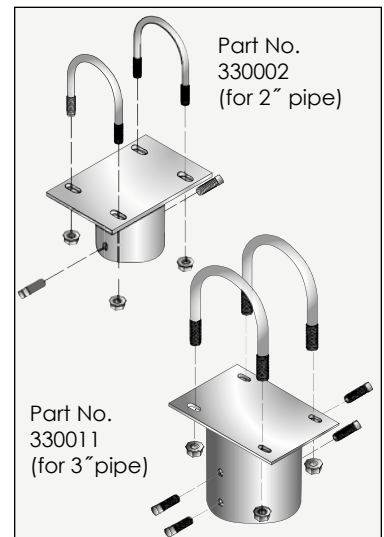


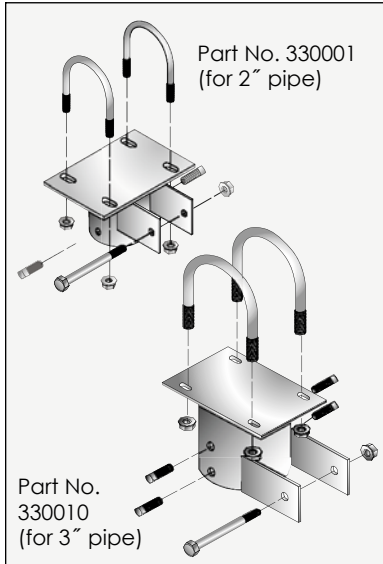
**1. SolarMount rail**—Standard or HD (heavy duty) rails support PV modules.

**2. Rail bracket**—Attaches rail to horizontal pipes. Includes 3/8-inch hardware: 1 U-bolt, 3 hexhead bolts, and 5 flange nuts.

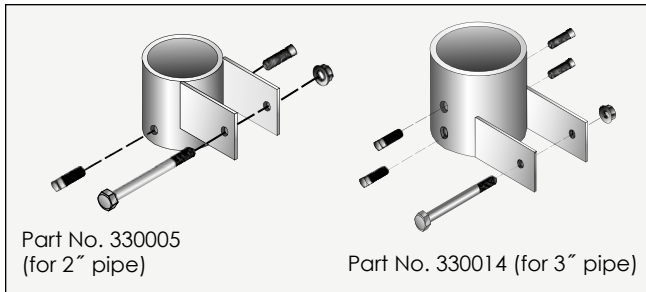


**3. Rear cap**—Attaches back horizontal pipe to vertical pipes. Includes 3/8-inch hardware: 2 U-bolts sized for pipe and 4 flange nuts, and 2 or 4 set screws.

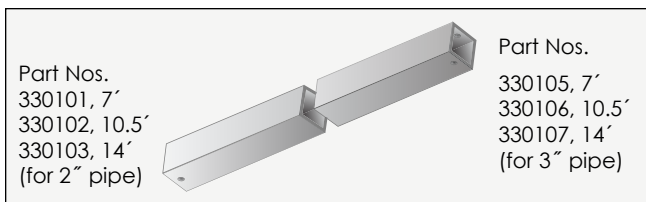




4. **Front cap**—Attaches front horizontal pipe to vertical pipes and anchors upper end of north-south braces. Includes  $\frac{3}{8}$ -inch hardware: 2 U-bolts and cross-brace bolt sized for pipe, 5 flange nuts, and 2 or 4 set screws.

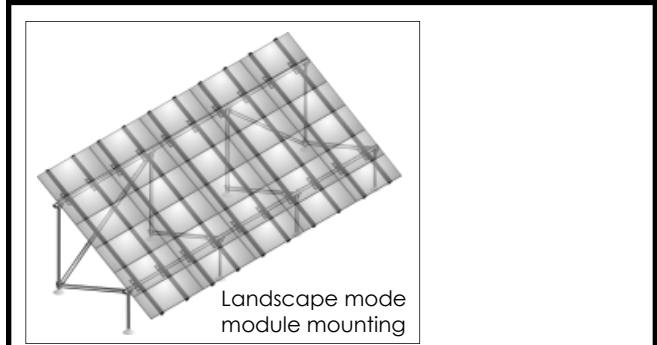


5. **Slider**—Attaches lower end of north-south cross braces to rear legs. Anchors both ends of east-west braces (if employed in your installation). Includes  $\frac{3}{8}$ -inch hardware: 1 cross-brace bolt sized for pipe, 1 flange nut, and 2 or 4 set screws.



6. **Cross Brace**—Provides north-south and east-west diagonal bracing. Extrusion size matches other 2- or 3-inch components.

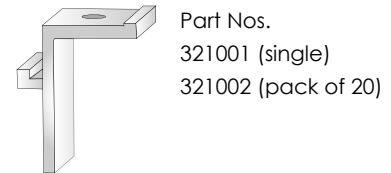
*Be prepared to cut and redrill braces on the jobsite.*



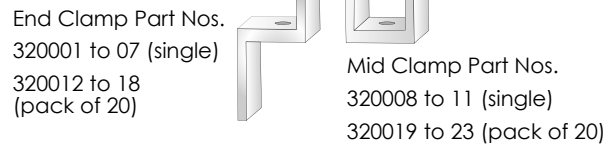
**Figure 2: Module mounting systems**

Your Specs Sheet (“Array Specifications,” p. 1) will list one of the following module-mounting systems for your installation:

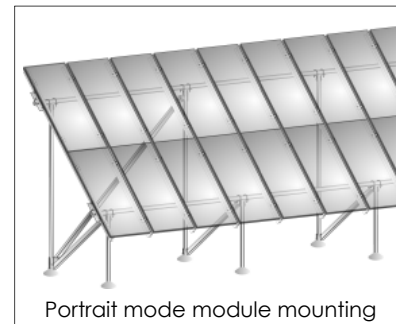
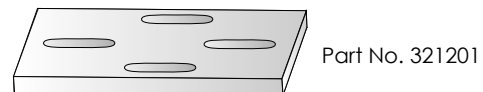
**Bottom mounting clip**—Mounts modules in landscape mode.



**Top mounting end clamp and mid clamp**—Mounts modules in landscape mode.



**Junction plate**—Mounts modules in portrait mode.



## Material specifications

**Rails, rail brackets, cross braces, bottom mounting clips, and top mounting clamps**—6105-T5 aluminum extrusion.

**Junction plates**—6061-T6  $\frac{1}{4}$ " aluminum.

**Caps and sliders**—Severe Condition 4 (very severe) zinc-plated welded steel.

**Fasteners**—304 stainless steel.

**Horizontal and vertical pipe** (installer supplied)—Minimum requirement of ASTM A53B Schedule 40 galvanized steel pipe in 2" or 3" diameter.

**Concrete** (installer supplied)—Rated for a minimum of 2,500 pounds per square inch.

## Planning the array prior to installation

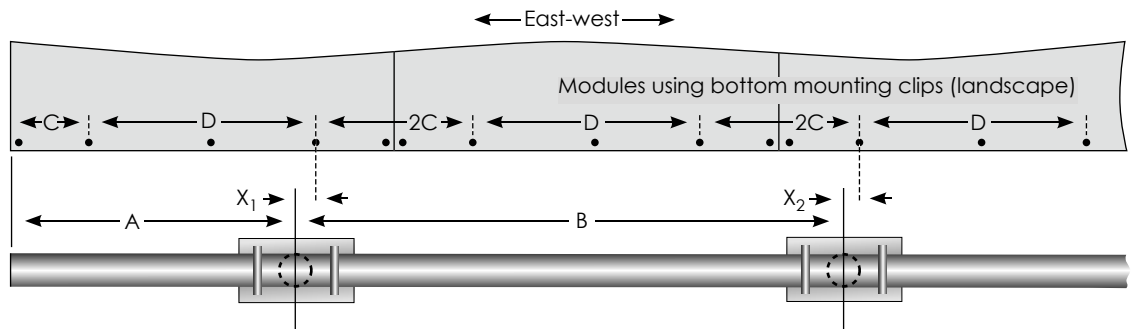
On a U-LA truss structure, leg caps, rail brackets, and cross pipe couplers must be offset from one another in the east-west direction. If you are using top mounting clamps, any conflicts among these components can be dealt with easily on site, so there is never the need to deviate from the average east/west leg spacing listed on your Specs Sheet. Go on to “Lay out and excavate leg positions,” below.

**If you are using bottom mounting clips or junction plates, there is a small chance that a conflict will require you to deviate slightly from the listed average leg spacing.** Make a scale drawing to identify potential component conflicts (see Fig. 3 or Fig. 4). If one occurs, use one or more of these solutions:

- Select a different set of module holes to mount your modules (an option available for bottom mounting clips only).
- Shift the position of conflicting pair of legs without exceeding maximum leg spacing listed on your Specs Sheet.
- Shift all cross pipes and rails relative to the legs without exceeding maximum cross pipe overhang listed on your Specs Sheet.

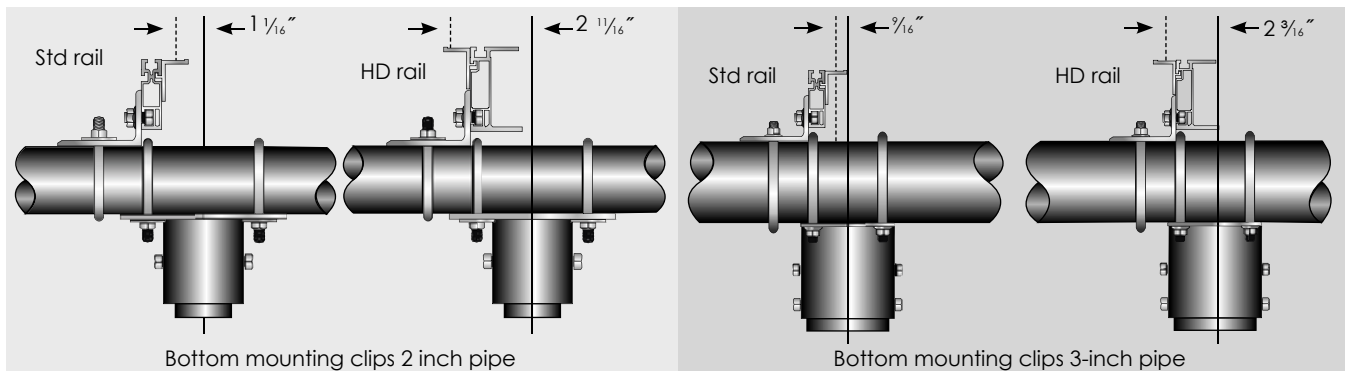
Cross pipe coupler conflicts and minor conflicts between leg caps and rail brackets, where offsets are near but not below the minimums listed in Figure 3 or 4, can be dealt with easily on site.

**Figure 3.**  
Planning installs with bottom mounting clips

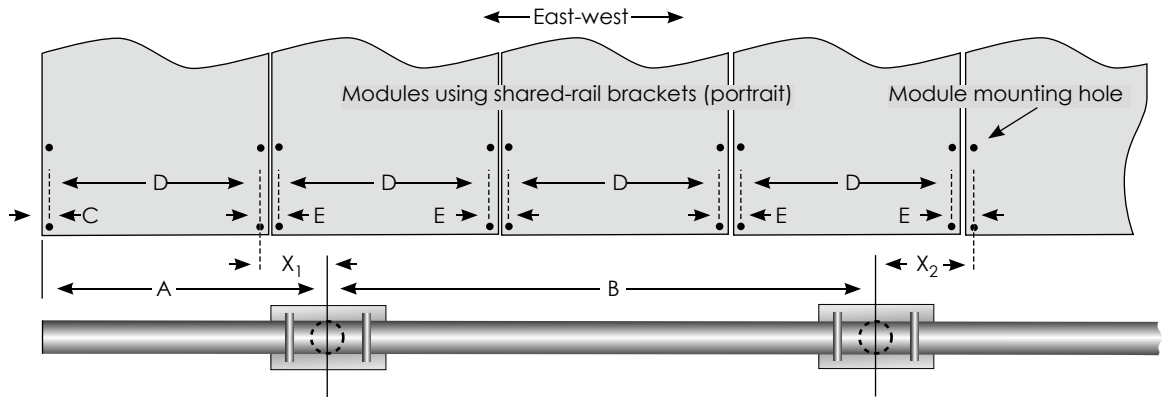


Create a dimensional drawing that lists overhang (A) and average leg spacing (B), which are listed under “Design Parameters” on page 2 of your Specs Sheet. Determine east-west offsets between vertical legs (dotted circles) to the module mounting holes you intend to use.

C and D depend on your specific modules. Determine your offsets (X<sub>1</sub>, X<sub>2</sub>, etc.). If the offsets are less than the applicable minimum offset below, you will need to slightly shift leg positions. Be sure to keep within maximum allowable spacing.

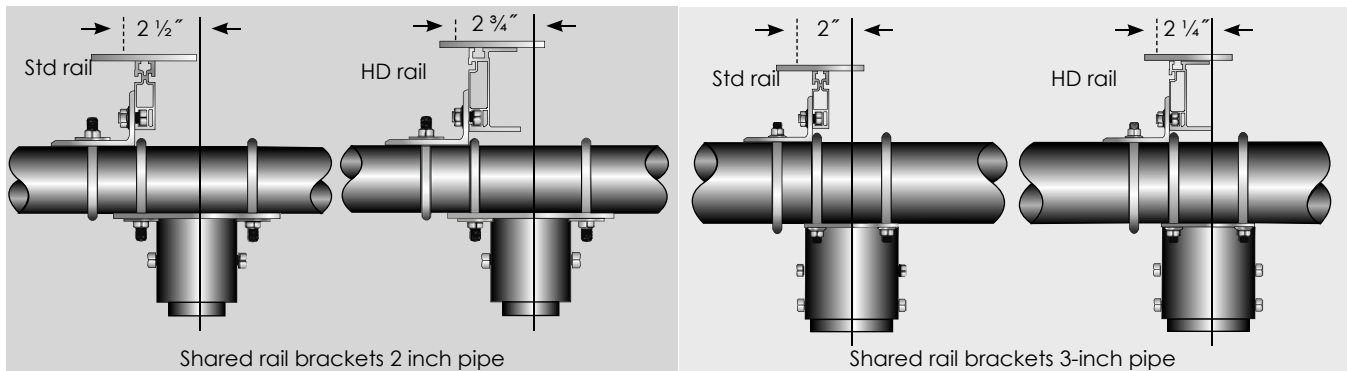


**Figure 4.**  
**Planning**  
**installs**  
**with**  
**junction**  
**plates**



Create a dimensional drawing that lists overhang (A) and average leg spacing (B), which are listed under “Design Parameters” on page 2 of your Specs Sheet. Determine east-west offsets between vertical legs (dotted circles) to the module mounting holes you intend to use. C and D depend on your specific modules. For standard rail, E equals 2C plus 5/8 inches (about 2 inches). For HD rail, E equals C

plus 1 7/8 inches (about 2 1/2 inches). Always measure the offsets (X<sub>1</sub>, X<sub>2</sub>, etc.) from the farther of the two mounting holes. If the offsets are less than the applicable minimum offset below, you will need to slightly shift leg positions. Be sure to keep within maximum allowable leg spacing.

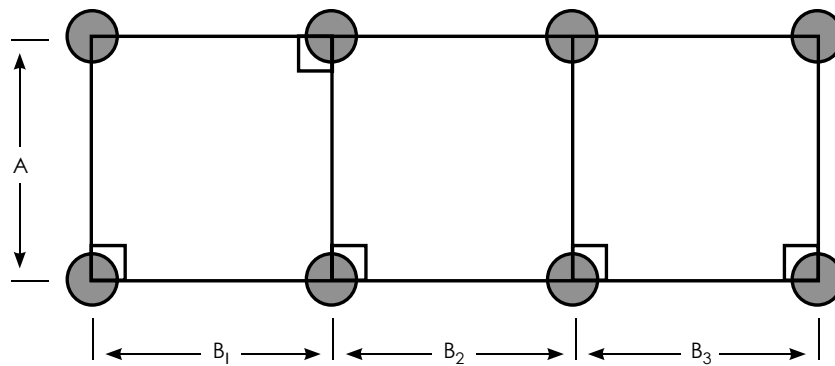


## Lay out and excavate leg positions

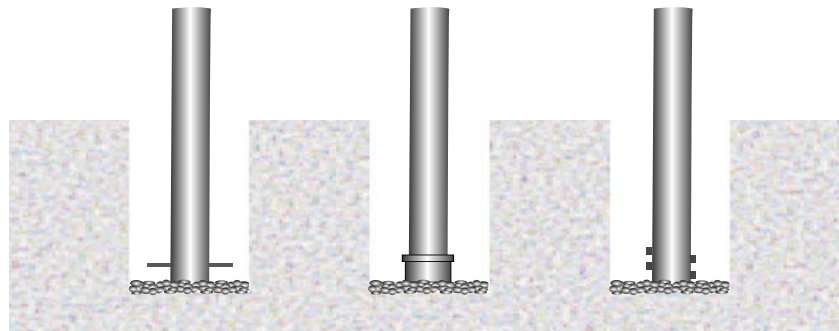
Establish your leg locations at the installation site. The north-south leg spacing (A) and east-west spacing (B) are listed under “Design Parameters” on page 2 of your Specs Sheet.

Once the grid of leg positions has been established, verify that all angles are square.

Dig leg holes to the “Footing diameter” and “Footing depth” listed on page 2 of your Specs Sheet. If you need to promote drainage, go a few inches deeper and fill the difference with gravel.



**Figure 5.** North-south leg spacing is fixed and listed on your Specs Sheet (Specific Values under “Design Parameters,” p. 2). East-west spacing ( $B_1$ ,  $B_2$ , etc.) is identical in most installations; see “Average leg spacing e-w” (Nominal Values under “Design Parameters”) on page 2 of your Specs Sheet. However, if you needed to shift leg positions, follow the east-west spacing you set during your planning session.



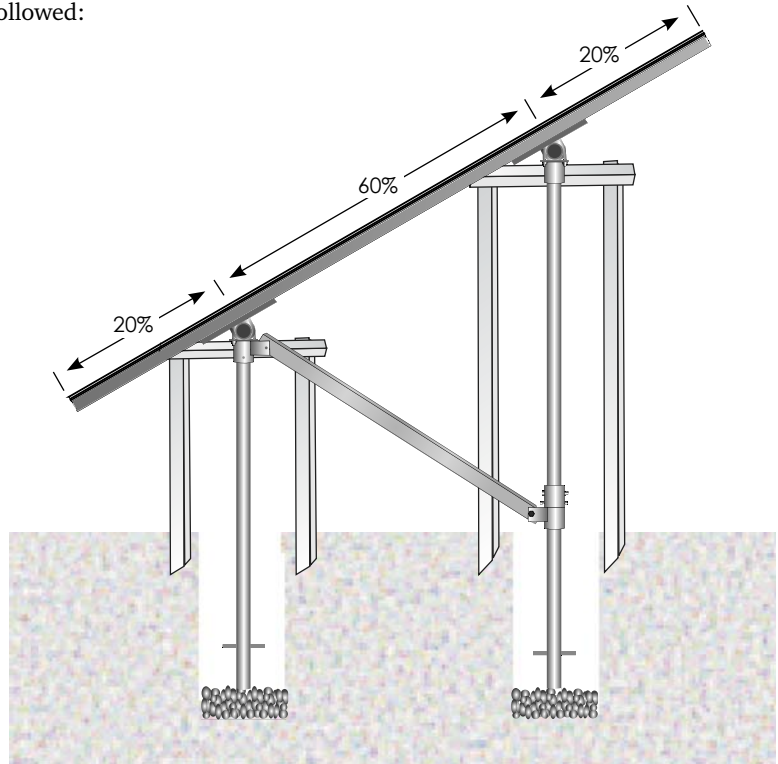
**Figure 6.** A length of rebar, a threaded cap, or bolts must be installed at the foot of the vertical pipes to prevent withdrawal of the footing.

## Select an assembly sequence

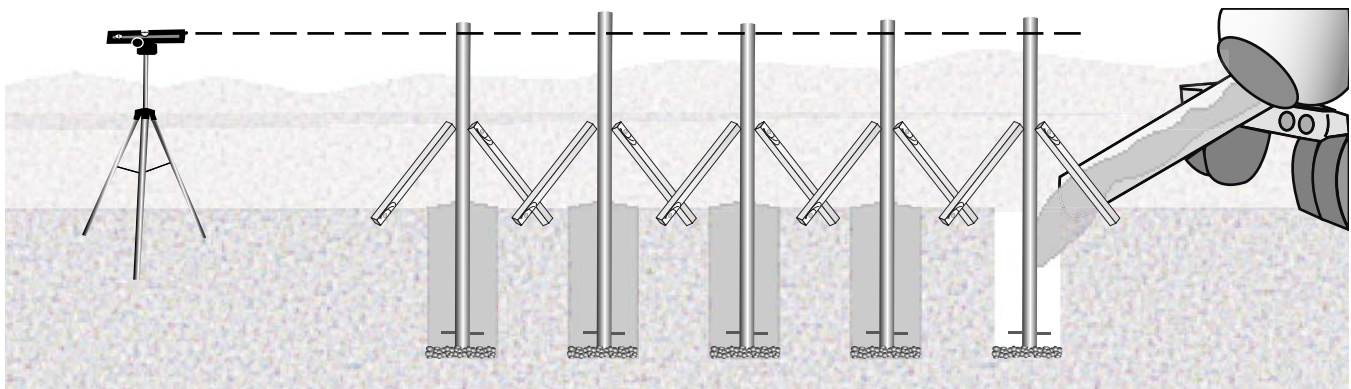
The assembly sequence depends on installer preference and the size of the installation. Either of these options may be followed:

- If a U-LA has just a few pairs of legs, installers may prefer to assemble the full truss structure prior to pouring concrete. Figure 7 details this approach.
- On the larger U-LA structures with many pairs of legs, installers may prefer to place the vertical leg pipes, pour the concrete, and let it cure overnight before proceeding. Figure 8 details this approach.

In either case, when mounting rails be sure to center them on the horizontal pipes, which will leave about 20 percent overhang on north and south sides.



**Figure 7. FULL-TRUSS OPTION.** Footing holes should extend below the frost line. You may elect to use a few inches of gravel at the base of the holes to promote drainage. Loosely assemble the full truss structure, using wood supports to stabilize vertical and horizontal pipes. When cross braces and rails are in place, square up the array and tighten fasteners. Pour concrete after array is fully assembled, save for the modules themselves. See page 8 of this manual for installation notes.



**Figure 8. LEGS-FIRST OPTION.** Footing holes should extend below the frost line. You may elect to use a few inches of gravel at the base of the holes to promote drainage. Using wood supports, level and square vertical leg pipes. Be certain that legs are precisely aligned

and that the front and back rows are parallel. Pour cement and allow to cure overnight before proceeding. Sighting with a laser level, transit, or string line, even the tops of the poles. See page 8 of this manual for installation notes.

## Installation notes

Regardless of your assembly procedure, review these notes prior to installation and keep them handy for reference on site.

### Shape concrete pillars for drainage

Slope concrete away from the legs to promote drainage. This can be done above ground or slightly below the surface. **Be sure footings extend below the frost line.**

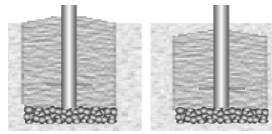


Figure 9. Drainage options.

### Don't forget your sliders!

A forgotten or misplaced sliding truss anchor can result in extensive disassembly. To avoid this needless labor, be sure that all sliders are in place and correctly oriented.

### Rail assembly options for landscape mode

All three modules mounting systems facilitate assembly of rails to the truss structure prior to mounting the PV modules. Bottom mounting clips and top mounting clamps provide an additional option: full north-south rows of modules can be assembled to rails prior to mounting rails to the truss structure. This option allows prefabrication and preliminary wiring—even off site, if desired.

### Recommended torques for fasteners

- Set screws for leg caps and sliders: 30 foot-pounds.
- 3/8-inch flange nuts for U-bolts on rail brackets: 20 foot-pounds.
- 3/8-inch flange nuts for rail brackets and other U-bolts: 30 foot-pounds.
- 1/4-inch module mounting hardware: 15 foot-pounds

### Pipe coupler positions

Remember that cross pipe couplers need to be offset from both leg caps and rail brackets. As a general guideline, place pipe couplers one-quarter to one-third of the way between leg caps and roughly midway between rail brackets.

### Minor conflicts between leg caps and rail brackets

Rail brackets, rails, and module mounts can go together in several ways. If a pair of rail brackets conflicts with leg cap positions, consult the table below. For top mounting clips or junction plates, Figures 3 and 4 (pp. 4–5) illustrates the arrangements allowing the least offset between module mounting holes and leg pipe centers.

#### Solutions to minor conflicts between leg caps and rail brackets

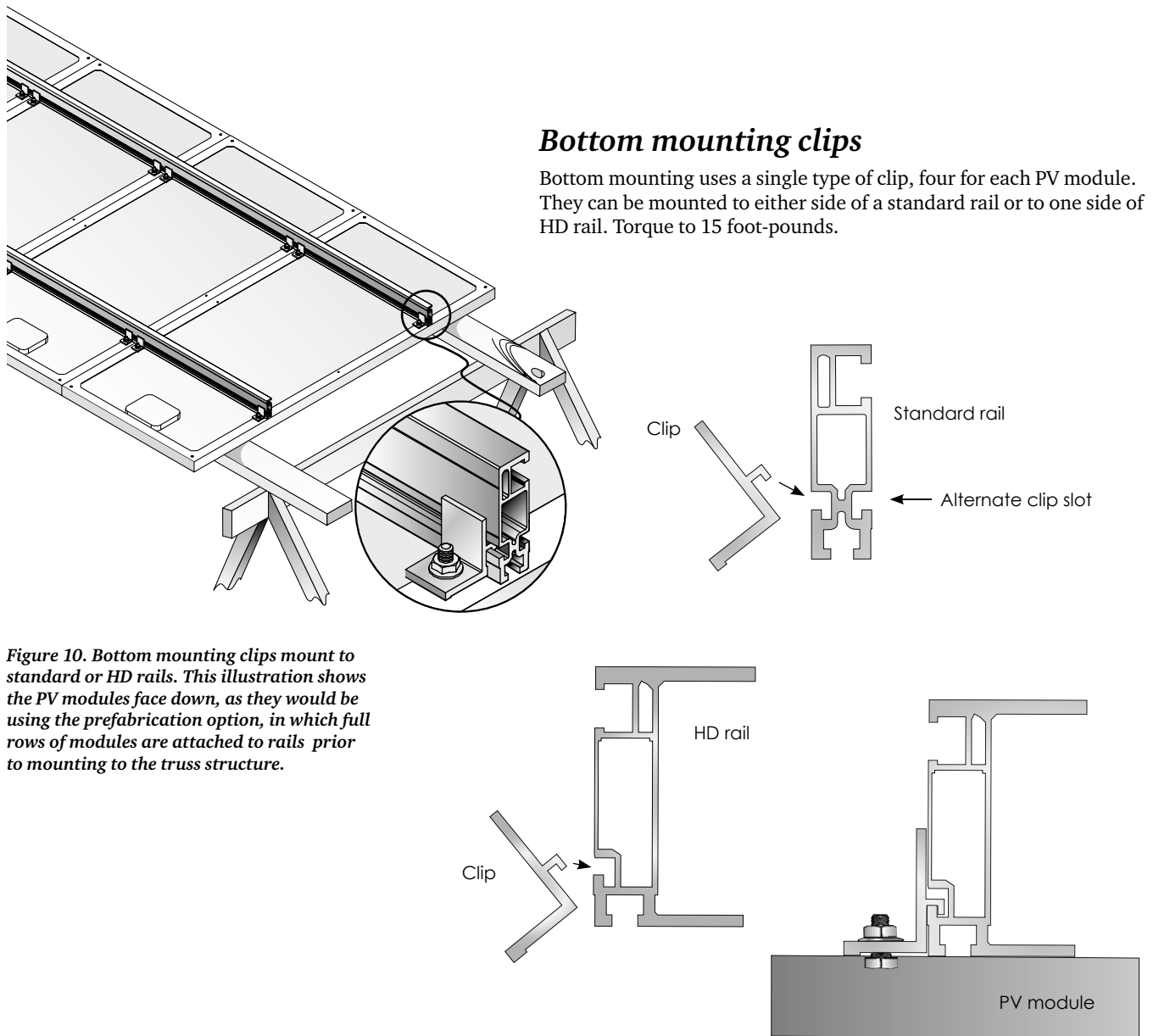
Module mounting style	Solutions (employ one or more as needed)
Top mounting clamps (landscape)	Shift rail toward the end of the module, reversing (if necessary) rail bracket and rail and moving them to the other side of the leg cap.
Bottom mounting clips (landscape)*	<ol style="list-style-type: none"> <li>1. Move mounting clips to other side of rail (standard rail only; see Fig. 10, p. 9).</li> <li>2. Reverse rail bracket and rail, moving them to the other side of the cap.</li> <li>3. Shift rail and use module mounting holes nearest the end of the module.</li> </ol>
Junction plates (portrait)*	Reverse rail bracket and rail, moving them to the other side of the cap.

\*Rail brackets, rails, and module mounts can be configured in several ways. Figures 3 and 4 (pp. 4–5) illustrates the arrangement that permits the least offset between rail brackets and leg caps.



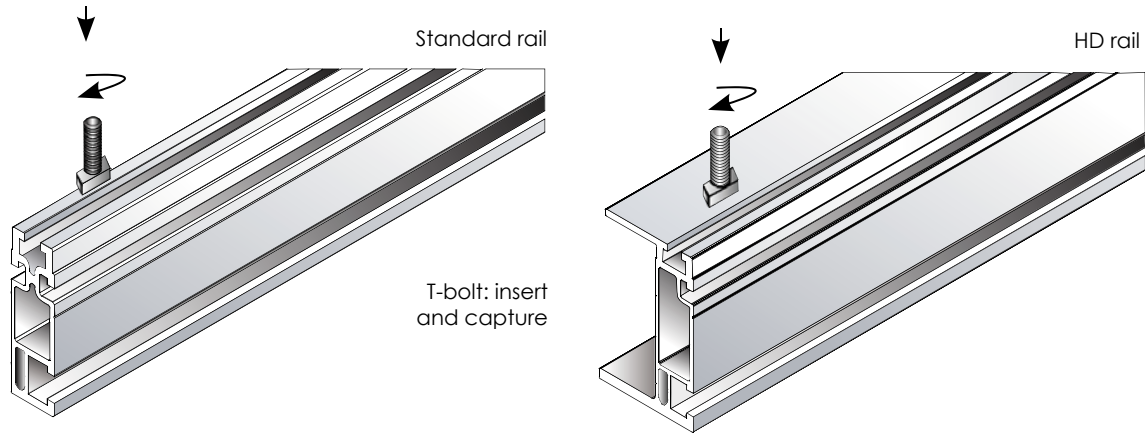
## Attach modules

Module mounts—bottom mounting clips (below), top mounting clamps (p. 10), or junction plates (p. 11)—are shipped with your rail sets. All employ ¼-inch mounting hardware.

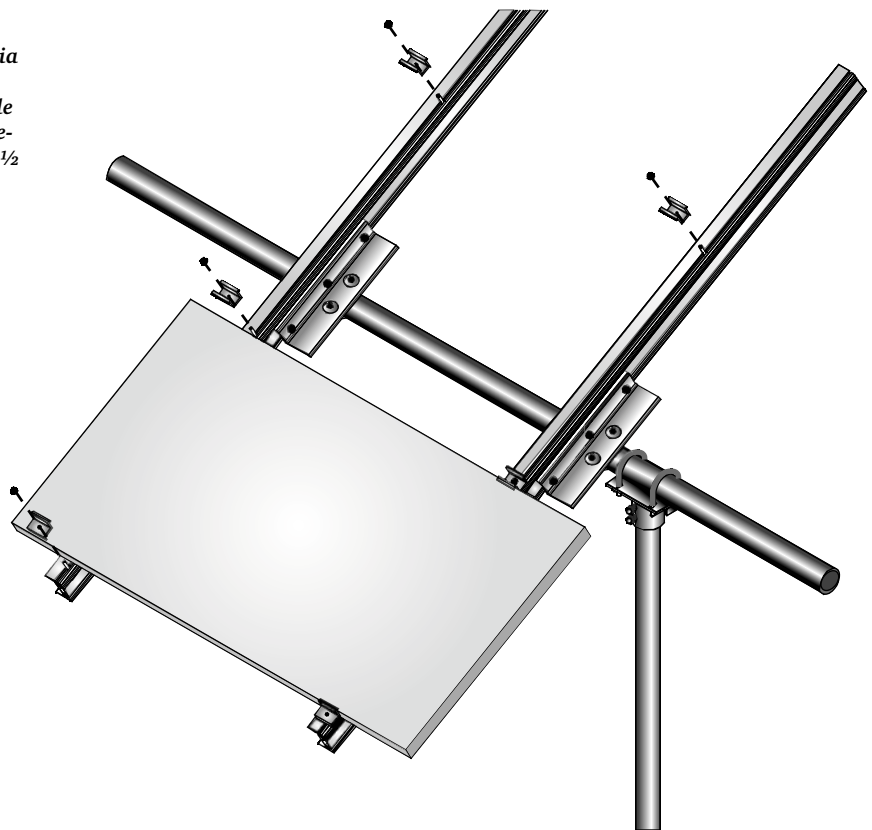


### Top mounting clamps

Top mounting end clamps (four per north-south row) and mid clamps (two at each module abutment within a row) secure PV modules without using module mounting holes. Mounting bolts slide into the top slot of either standard or HD rail. Torque to 15 foot-pounds.

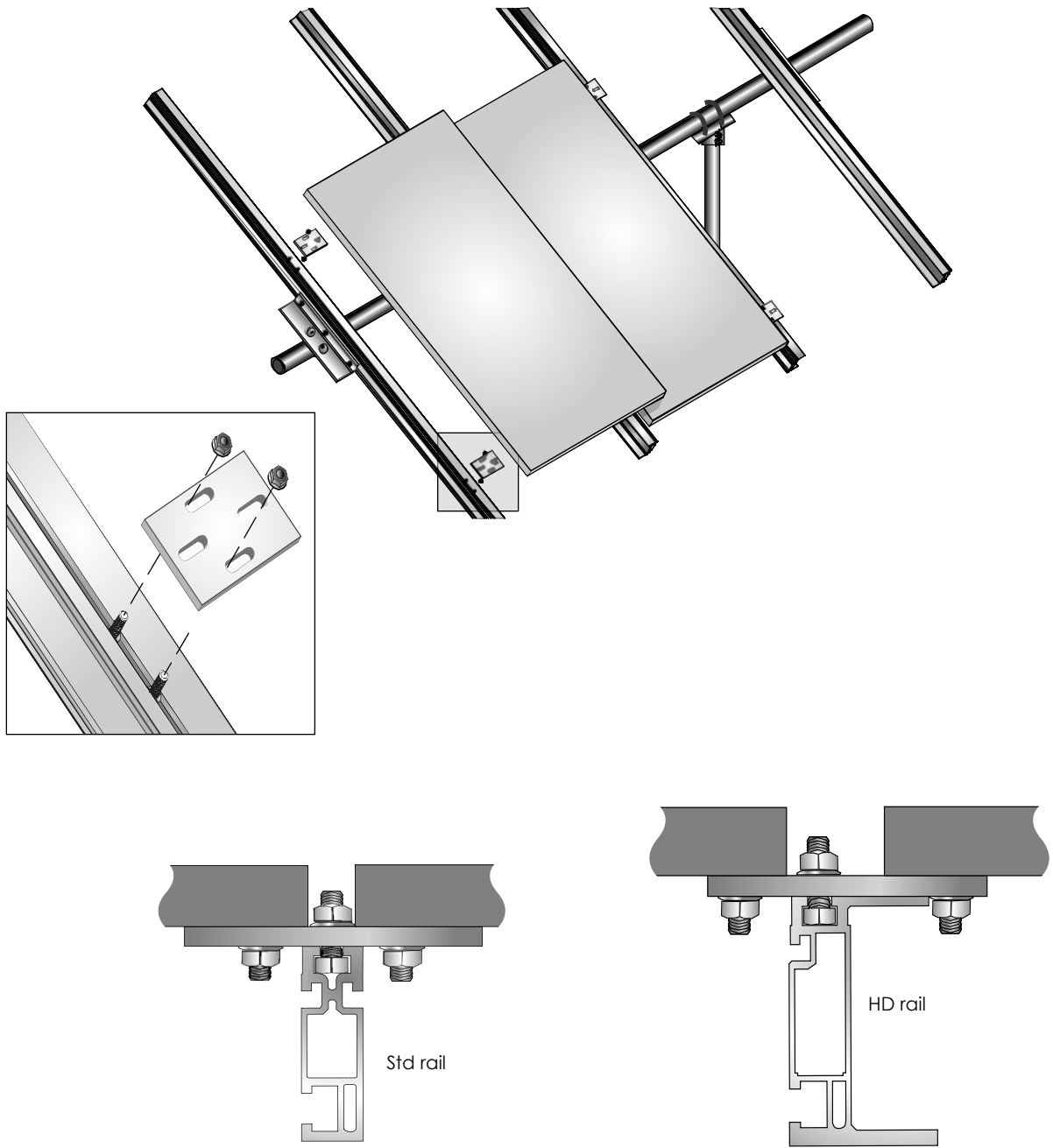


*Figure 11. Top mounting employs end clamps and mid clamps . They mount via T-bolts to standard or HD rail and are not dependent on the position of module mounting holes. One inch is required between modules and rails must extend 1½ inches beyond modules on each end.*



### Junction plates

Each junction plate mounts to standard or HD rails using two hexhead bolts. Be sure that the plate slots are perpendicular to the rail. Snug the modules together as closely as possible (especially with standard rail), which may require loosening the rail bracket flange nuts and shifting the rail slightly. Torque module mounting flange nuts to 15 foot-pounds.



**Figure 12.** Junction plates fasten via hexhead bolts to standard or HD rail. Modules are then supported on both sides and secured with module mounting bolt and flange nuts. For both rail types, plates must be oriented with their slots and long side perpendicular to the rail.

## 10 year limited Product Warranty, 5 year limited Finish Warranty

---

UniRac, Inc., warrants to the original purchaser ("Purchaser") of product(s) that it manufactures ("Product") at the original installation site that the Product shall be free from defects in material and workmanship for a period of ten (10) years, except for the anodized finish, which finish shall be free from visible peeling, or cracking or chalking under normal atmospheric conditions for a period of five (5) years, from the earlier of 1) the date the installation of the Product is completed, or 2) 30 days after the purchase of the Product by the original Purchaser ("Finish Warranty").

The Finish Warranty does not apply to any foreign residue deposited on the finish. All installations in corrosive atmospheric conditions are excluded. The Finish Warranty is VOID if

the practices specified by AAMA 609 & 610-02 – "Cleaning and Maintenance for Architecturally Finished Aluminum" ([www.aamanet.org](http://www.aamanet.org)) are not followed by Purchaser. This Warranty does not cover damage to the Product that occurs during its shipment, storage, or installation.

This Warranty shall be VOID if installation of the Product is not performed in accordance with UniRac's written installation instructions, or if the Product has been modified, repaired, or reworked in a manner not previously authorized by UniRac IN WRITING, or if the Product is installed in an environment for which it was not designed. UniRac shall not be liable for consequential, contingent or incidental damages arising out of the use of the Product by Purchaser under any circumstances.

If within the specified Warranty periods the Product shall be reasonably proven to be defective, then UniRac shall repair or replace the defective Product, or any part thereof, in UniRac's sole discretion. Such repair or replacement shall completely satisfy and discharge all of UniRac's liability with respect to this limited Warranty. Under no circumstances shall UniRac be liable for special, indirect or consequential damages arising out of or related to use by Purchaser of the Product.

Manufacturers of related items, such as PV modules and flashings, may provide written warranties of their own. UniRac's limited Warranty covers only its Product, and not any related items.

