

POLESIDES™

Series 4002 PV Module Rack with SolarMount™ Rails for 2½-Inch Pole

(Formerly Models U-PS/24 thru U-PS/44)

Installation Manual 409.3

U.S. and other patents pending.

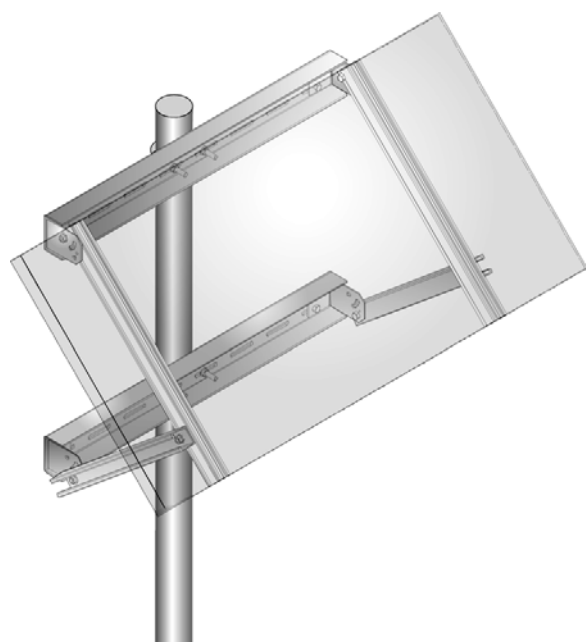

Thank you for purchasing a UniRac. Please read these guidelines completely before proceeding. This rack is intended for mounting on a 2½ inch Schedule 40 or Schedule 80 steel pole (27⁄8 inch O.D.), which is not included with the rack. UniRac can supply U-bolts for poles up to 4 inches at extra cost.

The installer is solely responsible for:

- Complying with all applicable local or national building codes, including any that may supersede this manual;
- Ensuring that UniRac and other products are appropriate for the particular installations and are designed for the installation environment;
- Using only UniRac parts and installer-supplied parts as specified by UniRac (substitution of parts will void the warranty);
- Ensuring safe installation of all electrical aspects of the PV array.

Parts List

Part	Qty	Wrench size	Recommended torque (ft-lbs)
SolarMount rail	2		
Channel	2		
Bracket, left-hand	2		
Bracket, right-hand	2		
Leg	2		
U-bolt, 3⁄8"	2		
Hex-head bolt, 3⁄8" x 1 1⁄4"	14	9⁄16"	30
Flange nut, 3⁄8"	18	9⁄16"	30
Bottom mounting clips	4*		
Module mounting bolt, 1⁄4" x 5⁄8"	4*	7⁄16"	15
Flange nut, 1⁄4"	4*	7⁄16"	15

Caution

Stainless steel hardware can seize up, a process called galling. To significantly reduce the likelihood of galling, apply a small drop of anti-seize lubricant to the threads of all bolts before installation. Anti-seize lubricants are readily available in auto parts and hardware stores. In their absence, any lubricant will reduce chances of galling.

*Per PV module to be mounted. The following models accommodate 1 module: 400204, 400206, 400235, 400236, 400237, and 400238. The following models accommodate 2 modules: 400208, 400209, 400210, and 400211.

Mounting Pole Guidelines for Series 4002 for 2 1/2-Inch Pole

The installer is solely responsible for use of the information below. These are general guidelines for normal installations with tilt angles up to 45 degrees. Greater tilt angle and these other variances can affect your installation:

- The required diameter and depth of the hole are dependent on soil type, which varies by locale. An installation in loose, sandy soil will require larger, deeper holes and, therefore, more concrete than an installation in soil of average density.
- The depth and width of the hole should also be increased in areas subject to winds in excess of 120 miles per hour, particularly if the location of the mounting pole is open and unprotected. Design wind speed in the table below assumes 29 psf wind force at 90 mph and 51 psf wind force at 120 mph, which correspond to Exposure Category C, terrain that is flat and generally open extending one-half mile or more from the site in any quadrant. More severe exposure—within a quarter-mile of open water, for example—will require greater in-ground pole depth and concrete volume.
- Poles taller than above-ground maximums listed here require that the depth of the hole be increased. Significantly taller poles may require a larger pole diameter than called for in the installation instructions for your UniRac.

If in doubt, consult a professional civil engineer who is familiar with local soil conditions and wind load requirements.

1. Dig the hole at least four inches deeper than required under “In-ground pole depth” in the chart below. Fill the hole with four inches of gravel to allow water drainage.

Total area of modules (sq. ft.)	Design wind speed (mph)	Maximum above-ground pole height (ft.)	Hole diameter (in.)	In-ground pole depth (in.)	Concrete volume (cu. ft.)
7	90	6	18	32	5
7	120	6	18	40	6
10	90	6	18	36	5.5
10	120	6	18	45	6.5
15	90	6	18	38	5.5
15	120	6	18	46	7
20	90	6	18	40	6
20	120	6	18	49	7

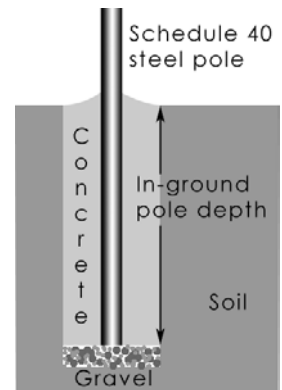

2. Stand the pipe in the hole. Brace the pole so that it is plumb. Pour concrete around the pipe, filling the hole to ground level. Add an inch or two of extra concrete above the hole. Use a trowel to form the concrete so that it slopes around the pole.
3. Allow the concrete to set up for at least 24 hours before installing your UniRac.

Assembly

Assembly order is not critical. You may work from the pole outward, or assemble the rack, PV module(s), and electrical components before mounting the assembly on the pole.

Loosely assemble all components.

Be certain that channel is centered on the pole and that the brackets sit with the pivot hole above the arc holes.

To attach modules, use clips and ¼ inch hardware. Be sure to center module relative to the channel.

If channel slots do not allow correct spacing and centering, apply one or more of these solutions:

- Move the clips to the other side of the rails.
- Move rails to the other side of the brackets.
- Reverse the positions of the left-hand and right-hand brackets.

Place the module(s) as close as possible to the pole end of the rails.

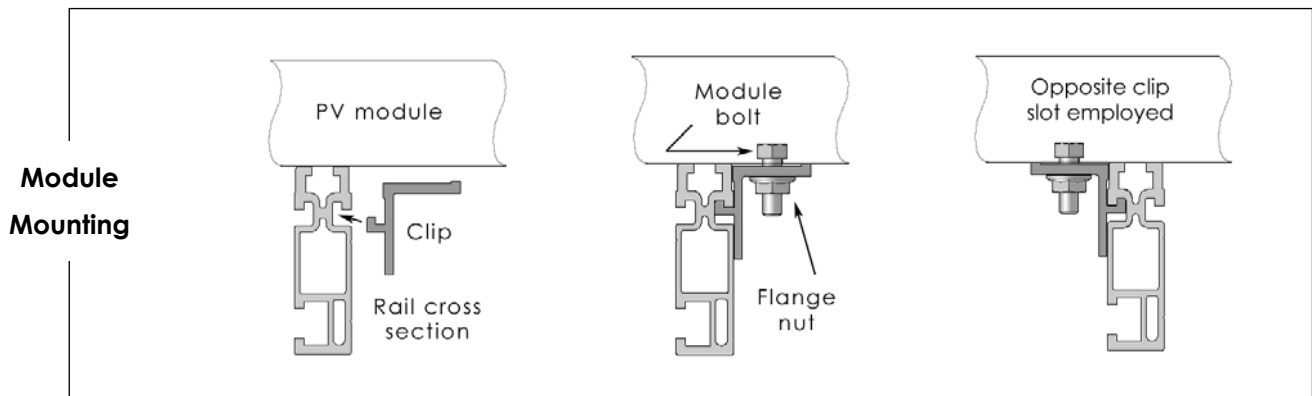
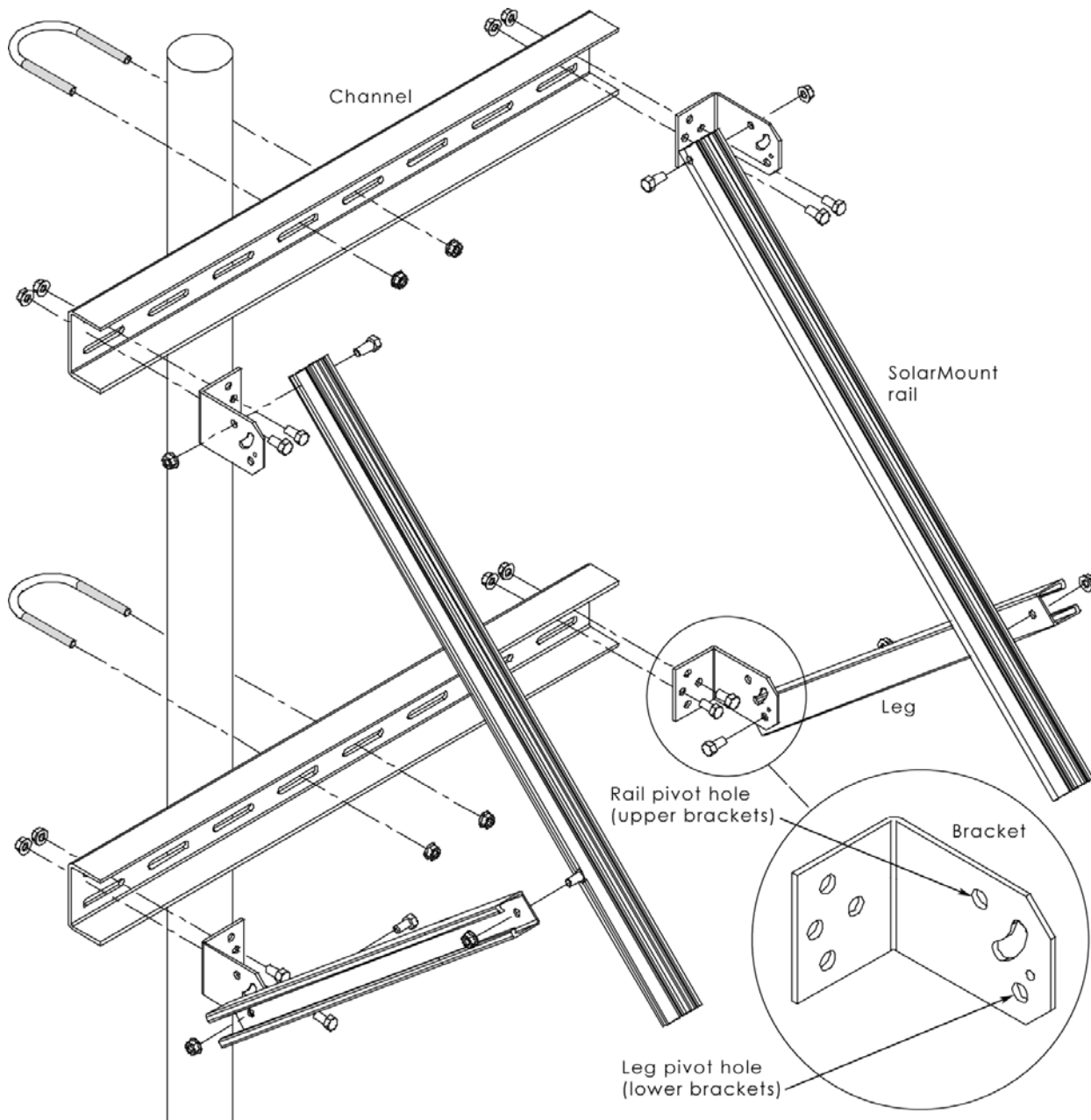

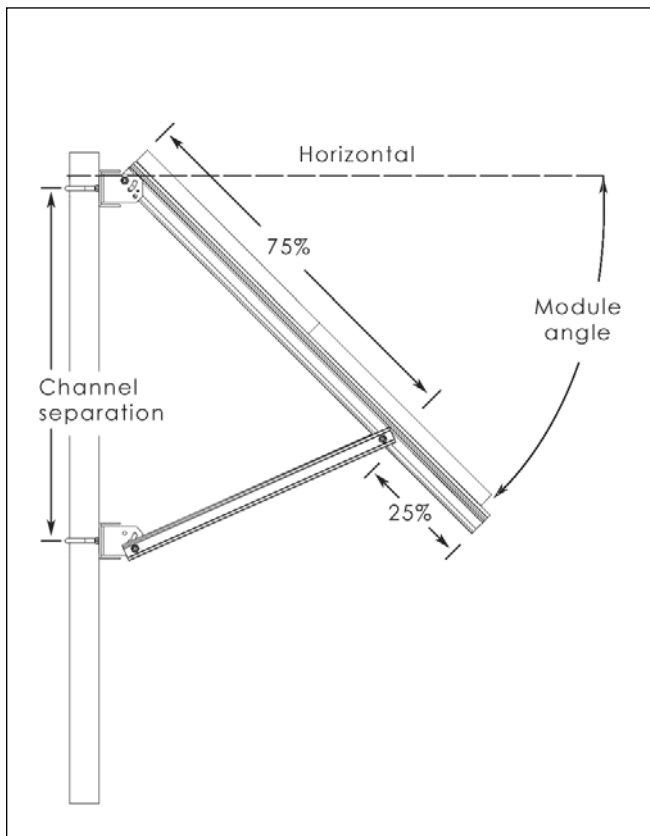

Final adjustment

The module angle depends on the distance between the channels. The table below lists the proper separation in inches for various rail lengths and desired module angles. UniRac does not recommend a module angle smaller than 30 degrees. **The angle between the rail and the leg must be no less than 60 degrees and no more than 90 degrees.**

To set the module angle to more than 45 degrees, UniRac recommends cutting and redrilling the legs as needed. Use an angle finder to set the rails at the desired angle. Be sure to maintain an angle between the legs and rails of no less than 60 and no more than 90 degrees.

Once satisfied with the module angle, tighten all fasteners in accordance with the torque specifications in the Parts List.

Channel Separation (inches)

Model	Rail length	Desired module angle			
		45°	40°	35°	30°
400204	28	30	28	25	21
400206	32	32	29	26	23
400208	40	43	39	35	30
400209	40	43	39	35	30
400210	44	47	43	38	33
400211	44	47	43	38	33
400235	28	30	28	25	21
200236	28	30	28	25	21
200237	32	34	31	28	24
200238	36	39	35	31	27

10 year limited Product Warranty

UniRac, Inc., warrants to the original purchaser ("Purchaser") of product(s) that it manufactures ("Product") at the original installation site that the Product shall be free from defects in material and workmanship for a period of ten (10) years, from the earlier of 1) the date the installation of the Product is completed, or 2) 30 days after the purchase of the Product by the original Purchaser. This Warranty does not cover damage to the Product that occurs during its shipment, storage, or installation.

This Warranty shall be VOID if installation of the Product is not performed in accordance

with UniRac's written installation instructions, or if the Product has been modified, repaired, or reworked in a manner not previously authorized by UniRac IN WRITING, or if the Product is installed in an environment for which it was not designed. UniRac shall not be liable for consequential, contingent or incidental damages arising out of the use of the Product by the Purchaser under any circumstances.

If within the specified Warranty period the Product shall be reasonably proven to be defective, then UniRac shall repair or replace the defective Product, or any part thereof,

in UniRac's sole discretion. Such repair or replacement shall completely satisfy and discharge all of UniRac's liability with respect to this limited Warranty. Under no circumstances shall UniRac be liable for special, indirect or consequential damages arising out of or related to use by Purchaser of the Product.

Manufacturers of related items, such as PV modules and flashings, may provide written warranties of their own. UniRac's limited Warranty covers only its Product, and not any related items.



THE NEW STANDARD IN PV MODULE RACKS™