

# Splices/Expansion Joints

## Installation Manual 908.1

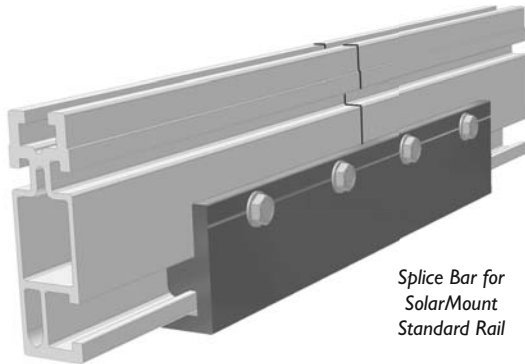

Splice Bar for  
SolarMount  
Standard Rail

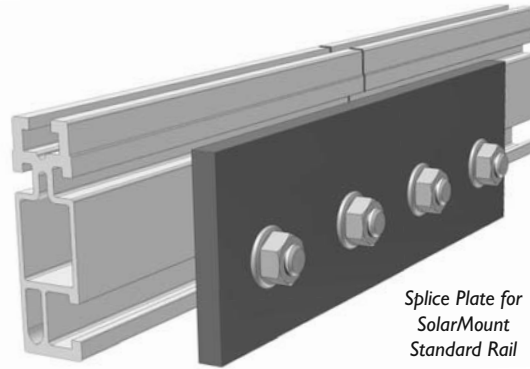

Splice Plate for  
SolarMount  
Standard Rail

### [1] Installer responsibility



#### The installer is solely responsible for:

- Complying with all applicable local or national building codes, including any that may supercede this manual;
- Ensuring that UniRac and other products are appropriate for the particular installation and the installation environment;
- Ensuring that the roof, its rafters, connections, and other structural support members can support the array under building live load conditions;
- Using only UniRac parts and installer-supplied parts as specified by UniRac (substitution of parts may void the warranty);
- Maintaining the waterproof integrity of the roof; and
- Ensuring safe installation of all electrical aspects of the PV array.

### [2] Applications

Splice bars are structural elements that may be used to join together lengths of one of the extruded aluminum rails used in UniRac products: SolarMount™ standard, SolarMount™ Light SolarMount™ HD (heavy duty), or SunFrame™.

Splice plates are also structural and may be used only with the two types of SolarMount rail.

Although structural, neither type creates a joint that is as strong as the rail itself. A rail should always be supported by **more than one** footing on **both** sides of the splice. (Manuals for code compliant planning and installation for SolarMount and SunFrame can be downloaded at the respective product pages at [www.unirac.com](http://www.unirac.com).)

Because of these support requirements, **never** use either type of splice in conjunction with the following applications:

- PV PoleTops™
- PV PoleSides™
- SolarMount arrays with high profile tilt legs
- U-LA large arrays



THE STANDARD IN PV MOUNTING STRUCTURES™

Pub 071105-1ii  
November 2007

See [www.unirac.com](http://www.unirac.com) for your nearest UniRac distributor.

UniRac welcomes input concerning the accuracy and user-friendliness of this publication. Please write to [publications@unirac.com](mailto:publications@unirac.com).

© 2007 by UniRac, Inc.  
All rights reserved.

In runs exceeding 45 feet of rail, UniRac recommends the use of expansion joints. Runs of rail less than 45 feet in length, with more than two pairs spliced together, are an acceptable installation for the SolarMount and SunFrame systems. As long as installations conform to the standard methods outlined in the Installation Manual 214 (SolarMount) and 808.1 (SunFrame), it will not void the UniRac warranty.

### Expansion joints

Expansion joints prevent buckling of rails due to thermal expansion. In runs of rail exceeding 45 feet, expansion joints are required. Only the splice bars, not splice plates, may be used for thermal expansion joints.

To create a thermal expansion joint, slide the splice bar into the footing slots of both rail lengths. Leave approximately half an inch between the segments. Secure the splice bar with two screws on one side only. Footings (such as L-feet or standoffs) should be secured normally on both sides of the splice.

No PV module or mounting hardware component should straddle the expansion joint. A string of modules must clearly end before the joint with mounting hardware (top mount clamps, or bottom up clips) terminating on that rail. The next string of modules would then commence following the splice with mounting hardware beginning on the next rail.

Exceptions may be allowable – contact UniRac.

### Caution

Stainless steel hardware can seize up, a process called galling. To significantly reduce the likelihood of galling, apply a small drop of anti-seize lubricant to the threads of all bolts before installation. Anti-seize lubricants are readily available in any auto parts and some hardware stores. In their absence, any lubricant will reduce chances of galling.

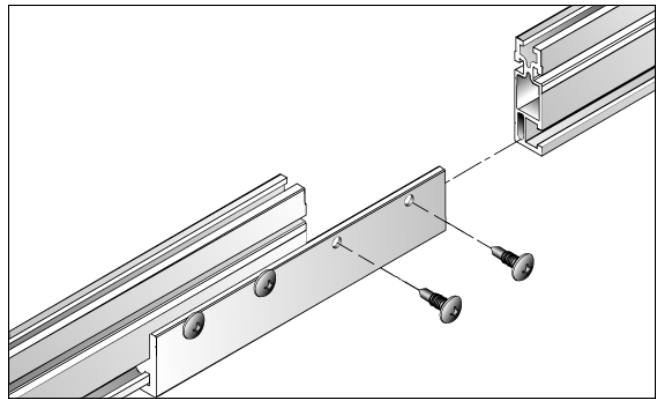

Splice bars slide into the footing bolt slots of SolarMount or SunFrame footing bolt slots. They are secured by No. 10 x 5/8-inch pan head screws. Expansion joints are secured on one side only.

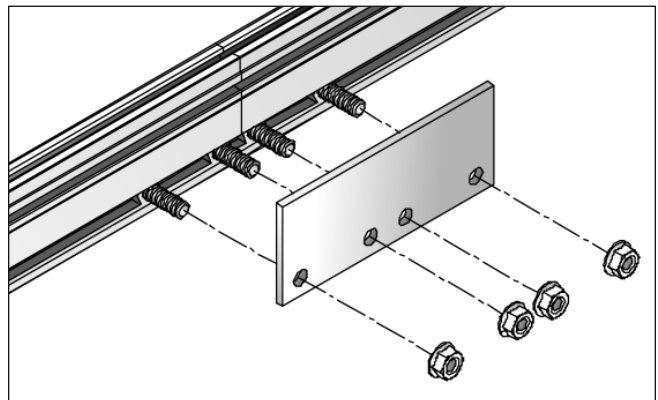

Splice plates are for use with SolarMount standard and HD rails only. Hexhead bolts slide into the footing slots of the rails. Flange nuts secure the plate.

## 10 year limited Product Warranty

UniRac, Inc., warrants to the original purchaser (“Purchaser”) of product(s) that it manufactures (“Product”) at the original installation site that the Product shall be free from defects in material and workmanship for a period of ten (10) years, from the earlier of 1) the date the installation of the Product is completed, or 2) 30 days after the purchase of the Product by the original Purchaser. This Warranty does not cover damage to the Product that occurs during its shipment, storage, or installation.

This Warranty shall be VOID if installation of the Product is not performed in accordance

with UniRac’s written installation instructions, or if the Product has been modified, repaired, or reworked in a manner not previously authorized by UniRac IN WRITING, or if the Product is installed in an environment for which it was not designed. UniRac shall not be liable for consequential, contingent or incidental damages arising out of the use of the Product by the Purchaser under any circumstances.

If within the specified Warranty period the Product shall be reasonably proven to be defective, then UniRac shall repair or replace the defective Product, or any part thereof,

in UniRac’s sole discretion. Such repair or replacement shall completely satisfy and discharge all of UniRac’s liability with respect to this limited Warranty. Under no circumstances shall UniRac be liable for special, indirect or consequential damages arising out of or related to use by Purchaser of the Product.

Manufacturers of related items, such as PV modules and flashings, may provide written warranties of their own. UniRac’s limited Warranty covers only its Product, and not any related items.



THE STANDARD IN PV MOUNTING STRUCTURES™